



**AGENDA**  
CITY OF SEASIDE  
NEIGHBORHOOD IMPROVEMENT  
COMMISSION

SPECIAL MEETING  
440 HARCOURT AVE  
Saturday, January 10, 2026  
8:00 AM

---

Virtual Participation Guide: <https://www.ci.seaside.ca.us/129/City-Council-Committee-Agendas>  
<https://ci-seaside-ca-us.zoom.us/j/81403301073> | WEBINAR ID 814 0330 1073 | (669) 900-9128

**1. CALL TO ORDER**

**2. ROLL CALL - NEIGHBORHOOD IMPROVEMENT COMMISSION**

Ray Riordan	Chair
Tiffinie Meyer	Vice Chair
Ramona Olaeta-Reed	Commissioner
Joan Costello	Commissioner
Shanda LeBeouf	Commissioner
Dennis Alexander	Commissioner
Stephanie Spross	Commissioner

**3. REVIEW OF AGENDA**

*If there are any items that arose after the 72-hour posting deadline, this is the point in the meeting where a vote may be taken to add the item to the agenda. (A 2/3-majority vote is required).*

**4. PUBLIC COMMENT**

*Members of the public wishing to address the Commission on matters within the jurisdiction of the City of Seaside, but not on this agenda, may do so during the Public Comment period for up to three (3) minutes. Comments on specific agenda items are heard under that item. For the public record, please state your name.*

**5. APPROVAL OF MINUTES**

**A. APPROVE MINUTES FROM NOVEMBER 4, 2025**

**6. BUSINESS**

**A. ELECTION OF CHAIR AND VICE CHAIR**

**B. ASSIGN NEIGHBORHOODS FOR THE HOUSE OF THE MONTH PROGRAM**

**C. DISCUSSION ON THE BI-ANNUAL BUSINESS OF THE QUARTER PROGRAM**

**D. DISCUSS COMMISSIONER ATTENDANCE AND PARTICIPATION AT CITY EVENTS AND FUNCTIONS**

**E. CONDUCT A STUDY SESSION ON THE FISCAL YEAR 2026/2027 WORK-PLAN**

**F. DISCUSSION ON THE BUDGET FOR PROJECT PROPOSALS**

**7. REPORTS FROM COMMISSIONERS**

This is a time specifically set aside for Commissioners to make brief comments of general interest to the community, make requests that items be added to future meeting agendas as necessary, and report on Committee Assignments.

**8. REPORTS FROM STAFF**

This is a time specifically set aside for the Staff Liaison to provide updates on non-agendized requests from the Commission, and to provide brief information on topics under the purview of the Commission.

**9. ADJOURNMENT**

Next Regularly Scheduled Meeting:  
February 3, 2026  
5:00 PM

---

The City of Seaside is committed to providing accessible facilities and accommodating people with disabilities in all of its services programs and activities. If special considerations are needed by any person to fully participate in this meeting, contact the City Clerk at (831) 899-6707 no fewer than two business days prior to the meeting to allow reasonable arrangements. Agendas and videos of past meetings are available on demand are posted at: <http://www.ci.seaside.ca.us/129/City-Council-Committee-Agendas>

Agenda-related writings or documents provided during public meetings are available for public inspection during the meeting or from the Office of the City Clerk. This agenda is posted in compliance with California Government Code Section 54954.2(a) or Section 54956.



## FINAL MINUTES

CITY OF SEASIDE  
NEIGHBORHOOD  
IMPROVEMENT  
COMMISSION

COUNCIL CHAMBERS  
Tuesday November 4, 2025  
5:00 PM

### 1. **CALL TO ORDER**

Commissioner Riordan called the meeting to order at 5:00 p.m.

### 2. **ROLL CALL - NEIGHBORHOOD IMPROVEMENT COMMISSION**

PRESENT: Riordan, Meyer, Alexander, Costello

ABSENT: Olaeta-Reed, LeBoeuf, Spross

### 3. **REVIEW OF AGENDA**

Commissioner Meyer proposed to add Item 5D. to discuss the NIC Retreat scheduled for November 15, 2025

*On motion by Commissioner Meyer and second by Alexander, and carried by the following vote, the Neighborhood Improvement Commission moved to approve adding Item 5 D. Discuss the NIC Retreat scheduled for November 15, 2025*

RESULTS: 4, 0, 0, 3

AYES: Riordan, Meyer, Alexander, Costello

NOES: None

ABSTAIN: None

ABSENT: Olaeta Reed, LeBoeuf, Spross

#### **PUBLIC COMMENT:**

None

### 4. **APPROVAL OF MINUTES**

#### **APPROVE MINUTES FROM OCTOBER 7, 2025**

*On motion by Commissioner Meyer and second by Costello, and carried by the following vote, the Neighborhood Improvement Commission moved to accept the October 7, 2025 Minutes with corrections in sentence 4 that Commissioner Costello stayed late and Commissioner Meyer noted her dumpster door wouldn't close.*

RESULTS: 4, 0, 0, 3  
AYES: Riordan, Meyer, Alexander, Riordin, Costello,  
NOES: None  
ABSTAIN: None  
ABSENT: Olaeta Reed, LeBoeuf, Spross

## **5. BUSINESS**

### **A. DISCUSSION ON PROVIDING YARD SIGNS FOR HOUSE OF THE MONTH RECIPIENTS AND PROVIDING PLAQUES FOR COMPLETED PROJECTS**

**RECOMMENDATION:** Have a discussion and provide feedback

Dan Meewis, Assistant City Manager, noted that while House of the Month winners are recognized at City Council meetings, not all recipients attend. He suggested that displaying a yard sign would increase visibility among local residents. The proposal includes displaying 3-4 signs for a month after the recipient receives the award, with the signs being picked up after 30 days. This initiative aims to encourage more residents to beautify their properties. A spreadsheet will be created to track the House of the Month winners.

#### **PUBLIC COMMENT:**

None

*On motion by Commissioner Meyer and second by Chair Riordan, and carried by the following vote, the Neighborhood Improvement Commission moved to approve to include 3-4-yard signs to recognize the House of the Month.*

RESULTS: 4, 0, 0, 3  
AYES: Riordan, Meyer, Alexander, Costello,  
NOES: None  
ABSTAIN: None  
ABSENT: Olaeta Reed, LeBoeuf, Spross

### **B. ESTABLISH CRITERIA FOR SELECTION OF THE BI-ANNUAL BUSINESS AWARDS**

**RECOMMENDATION:** Have a discussion and decide on criteria

Dan Meewis, Assistant City Manager, presented staff's recommendation for the Commission to review the proposed award categories and evaluation criteria for selecting future award recipients. He suggested that the Commission engage in a discussion on the

process and determine the next steps for the program.

#### Proposed Award Categories

1. Business of the Year – Recognizes an established business demonstrating overall excellence in operations, customer service, and community involvement.
2. New Business of the Year – Honors a business operating in Seaside for less than three years that shows innovation, growth, and promise.
3. Community Impact Award – Highlights a business contributing to Seaside’s social, cultural, or environmental wellbeing through volunteerism, sponsorships, or partnerships.
4. Beautification Award – Acknowledges businesses that have improved the physical appearance of their property or contributed to neighborhood beautification.
5. Sustainability Award – Recognizes businesses that integrate sustainable or environmentally conscious practices into their operations.

#### Proposed Selection Criteria

Businesses may be evaluated based on the following criteria (tailored to the applicable category):

- Community Engagement: Participation in or support for local events, youth programs, and community initiatives.
- Customer Service and Reputation: Demonstrated commitment to quality service, positive customer feedback, and ethical business practices.
- Innovation and Growth: Implementation of creative ideas, business expansion, or new products/services that enhance Seaside’s economy.
- Aesthetic Improvements: Efforts to enhance curb appeal, landscaping, signage, or building maintenance.
- Sustainability Practices: Actions that reduce waste, conserve energy, or promote environmentally responsible practices.
- Longevity and Stability: Years in operation, employee retention, and overall contribution to Seaside’s economic resilience.

Commissioner Costello suggested; Attractive interior and exterior, Friendly and Welcoming, Noticeable Improvements and Community Involvement

#### **Discussion:**

- Commissioner Alexander suggested adding "Locally Owned" as a criteria for consideration.
- Commissioner Meyer raised concerns about whether business owners who lease their properties are allowed to make upgrades to the interior and exterior.
- Commissioner Alexander proposed possibly excluding the "Interior" criteria, similar to the House of the Month program.
- Commissioner Meyer advocated for including both "Interior" and "Exterior" as criteria.
- Chair Riordan emphasized that "Customer Service" should also be part of the criteria.
- Commissioner Meyer noted that while McDonald’s is a franchise, it is locally owned, and raised the question of how involved locally owned franchises are in giving back to the community.

- Commissioner Costello stated that there is already enough criteria to work with.

**PUBLIC COMMENT:**

None

*On motion by Commissioner Alexander and second by Meyer, and carried by the following vote, the Neighborhood Improvement Commission moved to accept criteria framework including "Locally Owned".*

RESULTS: 5, 0, 0, 2

AYES: Riordan, Meyer, Alexander, Costello, Spross (arrived at 5:33)

NOES: None

ABSTAIN: None

ABSENT: Olaeta-Reed, LeBoeuf

**C. ESTABLISH CRITERIA FOR THE HOLIDAY LIGHTS CONTEST**

**RECOMMENDATION:** Have a discussion and decide on criteria

Dan Meewis, Assistant City Manager, mentioned that Parks and Recreation voted unanimously to partner again with the NIC for the Holiday Lights Contest. Three options for judging holiday lights:

1. **Top 3** – Select the top three displays overall.
2. **Category Winners** – Choose one winner for each of three categories.
3. **Scoring Sheet** – Rate each display based on a set of criteria.

**Proposed Categories:**

1. **Best Overall Display** – Most outstanding and cohesive holiday lights.
2. **Best Residential Display** – Creative, high-quality home decorations.
3. **Best Neighborhood Spirit** – Block, cul-de-sac, or complex with the best collective celebration.
4. **Most Creative Theme** – Unique, original theme or concept.
5. **Best Use of Lights** – Innovative lighting design and effects.

**Proposed Judging Criteria:**

Entries will be scored 1-5 based on:

- **Creativity & Originality** – Use of theme, color, and design.
- **Aesthetic Appeal** – Visual impact and holiday spirit.
- **Use of Lights & Decorations** – Safe, engaging lighting.
- **Theme Consistency** – Clear, cohesive presentation.
- **Community Impact** – Neighborhood pride and public enjoyment.

- **Sustainability (Optional)** – Use of energy-efficient or eco-friendly elements.

**PUBLIC COMMENT:**

None

*On motion by Commissioner Alexander and second by Meyer, and carried by the following vote, the Neighborhood Improvement Commission moved to approve to holding the judging for the Holiday Lights Contest on December 16, including the proposed criteria.*

RESULTS: 5, 0, 0, 2

AYES: Riordan, Meyer, Alexander, Costello, Spross

NOES: None

ABSTAIN: None

ABSENT: Olaeta Reed, LeBoeuf

**D. DISCUSS RETREAT THAT THE NIC HAS SCHEDULED ON SATURDAY, NOVEMBER 15.**

**RECOMMENDATION:** Have a discussion and provide feedback

Commissioner Meyer intended to attend but is unable to, and is requesting the option to either reschedule or keep the original retreat date. Additionally, Commissioner Spross and Liaison Dan Meewis are also unavailable to attend the November 15, 2025 retreat.

**PUBLIC COMMENT:**

None

*On motion by Commissioner Alexander and second by Costello, and carried by the following vote, the Neighborhood Improvement Commission moved to propose Retreat date for January 10, 2026 from 8-11 AM*

RESULTS: 5, 0, 0, 2

AYES: Riordan, Meyer, Alexander, Costello, Spross

NOES: None

ABSTAIN: None

ABSENT: Olaeta Reed, LeBoeuf

**6. REPORTS FROM COMMISSIONERS**

The Commissioners discussed and agreed to cancel the regular meeting scheduled for December 2nd. Instead, they will hold a special meeting on December 16, 2025,

in partnership with the PRC to participate in the Holiday Lights judging.

**7. REPORTS FROM STAFF**

Dan Meewis, Assistant City Manager, reported that the Seaside Stars inducted four new members at a successful event, which had the largest turnout to date and beautiful weather. Oldemeyer hosted a Halloween event, which, despite a lower turnout than expected, was still a fun and successful occasion. The Seaside City Hall Tree Lighting is scheduled for December 5 from 6-9 PM. The new Activity Guide has been released and is valid through May 2026, with program registration opening on December 7, 2025.

**8. ADJOURNMENT**

With no further business the meeting adjourned at 6:14 pm.

*On motion by Commissioner Alexander and second by Meyer, and carried by the following vote, the Neighborhood Improvement Commission moved to adjourn.*

**Respectfully submitted,**

---

**Jennifer Hancock, Committee Clerk**

---

**Ray Riordan, Chair**



**CITY OF SEASIDE  
STAFF REPORT**

**Item No.: 6.A.**

**TO:** Neighborhood Improvement Program  
**BY:** Dan Meewis, Assistant City Manager  
**DATE:** January 10, 2026  
**SUBJECT: ELECTION OF CHAIR AND VICE CHAIR**

---

**RECOMMENDATION**

Hold an election to select a Chair and Vice Chair for the upcoming year.

**BACKGROUND**

Every year the commission needs to select a new Chair and Vice Chair. This typically happens at the first or second meeting of the year. Commissioners will be able to nominate a fellow commissioner to serve in either role. If the nomination is accepted, a vote will be held to determine who will serve as the new Chair or Vice Chair.

**FISCAL IMPACT**

No fiscal impact with this item

**ATTACHMENTS**

None

---

---





**CITY OF SEASIDE  
STAFF REPORT**

**Item No.: 6.B.**

**TO:** Neighborhood Improvement Program

**BY:** Dan Meewis, Assistant City Manager

**DATE:** January 10, 2026

**SUBJECT: ASSIGN NEIGHBORHOODS FOR THE HOUSE OF THE MONTH PROGRAM**

---

**RECOMMENDATION**

**BACKGROUND**

The House of the Month Program recognizes residents who take pride in maintaining and enhancing the appearance of their homes and neighborhoods. The program is intended to promote community pride, neighborhood beautification, and positive recognition of residents.

To ensure fairness and consistency, neighborhoods are typically rotated so that all areas of the City have an opportunity to be considered. Assigning neighborhoods in advance allows the NIC and staff to plan outreach efforts and maintain a balanced distribution of recognition.

**ATTACHMENTS**

None

---





**CITY OF SEASIDE  
STAFF REPORT**

**Item No.: 6.C.**

**TO:** Neighborhood Improvement Program

**BY:** Dan Meewis, Assistant City Manager

**DATE:** January 10, 2026

**SUBJECT: DISCUSSION ON THE BI-ANNUAL BUSINESS OF THE QUARTER PROGRAM**

---

**RECOMMENDATION**

**BACKGROUND**

The Business of the Quarter Program is designed to recognize local businesses that contribute positively to the community through service, innovation, community involvement, or economic vitality. Under the current structure, the program operates on a bi-annual basis and highlights selected businesses through City recognition and outreach efforts.

Periodic review of the program allows the NIC to assess its effectiveness, ensure transparency in the nomination and selection process, and confirm alignment with the City's economic development and community engagement goals.

**ATTACHMENTS**

None

---





**CITY OF SEASIDE  
STAFF REPORT**

**Item No.: 6.D.**

**TO:** Neighborhood Improvement Program

**BY:** Dan Meewis, Assistant City Manager

**DATE:** January 10, 2026

**SUBJECT: DISCUSS COMMISSIONER ATTENDANCE AND PARTICIPATION  
AT CITY EVENTS AND FUNCTIONS**

---

**RECOMMENDATION**

**BACKGROUND**

City Commissioners play an important role in representing the City, supporting community engagement, and maintaining a visible presence at City-sponsored events and functions. This agenda item is intended to facilitate discussion by the Neighborhood Improvement Commission (NIC) regarding commissioner's attendance and participation at City events, including expectations, challenges, and opportunities to strengthen engagement and coordination. Input from the NIC will assist in clarifying best practices and identifying ways to encourage consistent and meaningful commissioner participation.

**ATTACHMENTS**

None

---



**CITY OF SEASIDE  
STAFF REPORT**

**Item No.: 6.E.**

**TO:** Neighborhood Improvement Program

**BY:** Dan Meewis, Assistant City Manager

**DATE:** January 10, 2026

**SUBJECT: CONDUCT A STUDY SESSION ON THE FISCAL YEAR 2026/2027  
WORK-PLAN**

---

**RECOMMENDATION**

Select projects or programs to recommend to the City Council for the Fiscal Year 2026/2027 work plan.

**BACKGROUND**

The Neighborhood Improvement Commission (NIC) is entrusted with and holds the duty of making recommendations to the City Council and advising the Council on matters pertaining to general improvement of the neighborhoods within the City. The main way this is achieved is through the commission's annual work-plan.

The NIC is allocated funding through the City's Transient Occupancy Tax (TOT), and with the allocated funding the commission is tasked with selecting projects that meet the criteria set forth in Chapter 2.24 of the City's Municipal Code. Those projects will be recommended to the City Council for approval. The estimated allocation for fiscal year 2026/2027 is between \$250,000 - \$350,000. In fiscal year 2025/2026, the commission was allocated \$311,924.

Some of the past projects are:

- Oldemeyer Center Mural
- Resurfacing of the Wheeler Street tennis courts and adding 4 pickleball courts
- Benches on General Jim Moore road
- Utility Box Art
- Lights for Palm Trees on Fremont
- Residential Tree Giveaway program

Each year the commission solicits input from other commissions and community groups for ideas,

and during their study session they will identify projects to move forward with and get more detailed information, including potential costs.

The NIC has received proposals from the following groups: Parks & Recreation Commission, Art \* History Commission, Homeless Commission, Friends of Seaside Parks Association, Sustainable Seaside, Seaside Public Works, and a community member.

## **FISCAL IMPACT**

## **ATTACHMENTS**

1. Homeless- SOLAR\_BENCH\_HANDOUT
  2. Homeless- SOLAR\_BENCH\_PROPOSAL
  3. NIC Recommendation-Homeless Co-2
  4. NIC Recommendations-Art & History Commission Project Ideas 26-27
  5. NIC Recommendations-Engineering Commission Project Ideas 26-27
  6. NIC Recommendations-Environmental Commission Project Ideas 26-27
  7. NIC Recommendations-Environmental Commission Report on Heermanns Gulls  
10.27.25
  8. NIC Recommendations-FOSPA Project Ideas 26-27
  9. NIC Recommendations-Parks & Recreation Commission Project Ideas 26-27
  10. NIC Recommendations-Private Citizen-Anthony Amarante Project Ideas 26-27
  11. NIC Recommendations-Private Citizen-Emily Gottlieb Project Ideas 26-27
  12. NIC Recommendations-Private Citizen-Lynda Cunningham Project Ideas 26-27
  13. NIC Recommendation-Seaside Community Safety Advisory Commission Project  
Ideas 26-27
  14. NIC Recommendations-Seaside Community Safety Advisory Commission PICTURES  
26-27
  15. NIC Recommendations-Sustainable Seaside Project Ideas 26-27
- 
-

# Proposal to City of Seaside

## Neighborhood Improvement Commission



### PROJECT PROPOSAL:

#### Solar-Powered Park Bench Charging Station

The Homeless Commission proposes the purchase of an outdoor solar-powered picnic-style park bench that serves as a charging station.

Location: Stephen Ross Park Grass area  
(between Library and City staff portables).

Current starting cost of one bench: \$6,999

### BENEFITS:

Provides outdoor charging support for community members (Phones, Laptops, Tablets, etc.).

Promotes Fellowship and offers a nice spot to relax in the shade.

Invites community to enjoy the park more frequently.

Offers modern conveniences.

Enhances park utilization.



# DESCRIPTION

## SunnyCal “Yosemite” Solar-Powered Picnic Table

Concrete solar powered picnic table designed for remote outdoor locations.

Provides two 120 volts AC outlets and six standard USB outlets.

Weather and vandal resistant.

Ready for use upon delivery. No setup Required.

Twenty year expected service life.

## FEATURES:

(2) 120v receptacles and (6) USB outlets.

4-panel 800 watt solar module array and charge controller.

300 watt daytime inverter.

GFCI protection and UL listed NEMA receptacles to prevent electrical shock in case of rainy weather.

Optional 1,440 Watt/Hour battery for use when the sun is down (unlocks additional features).

Optional automatic LED table lights (must have battery) (\$144).

Optional Host 911 Emergency Phone (must have battery) (\$1,508).

Optional tamper-resistant solar panel screws (\$340).

## STRUCTURE:

Industrial Strength Cast Reinforced Concrete table.  
Easy to Clean.

Seats up to 8 comfortably with ADA compliant seating on both ends .

Engineered pole mount system.

Stainless steel welded frame.

90mph wind speed rated.

Robust Ballast mount system minimizes panel movement.

Optional tamper-resistant solar panel screws.

Heavy-duty components.



# DIMENSIONS:

Canopy Height (High side) : 9ft adjustable

Canopy head clearance (low side): 6ft 6in

Table: 7ft-8in long x 5ft-5in wide x 2ft- 8in high

Canopy: 6ft-9in long x 4ft 10in wide

Total weight: 2,650lbs (can be placed on grass, gravel or concrete.)

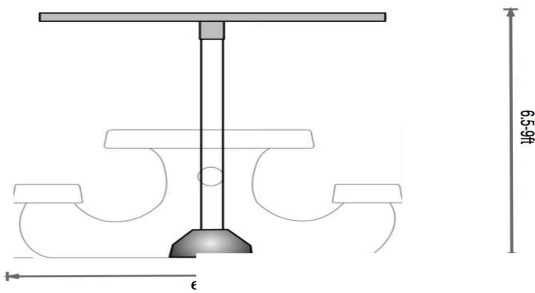
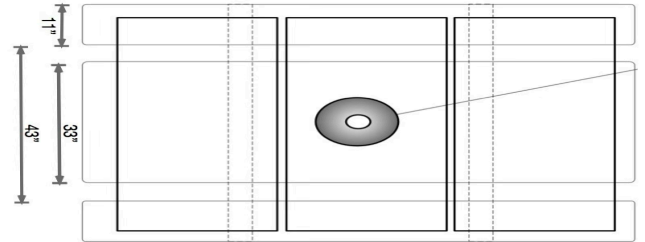
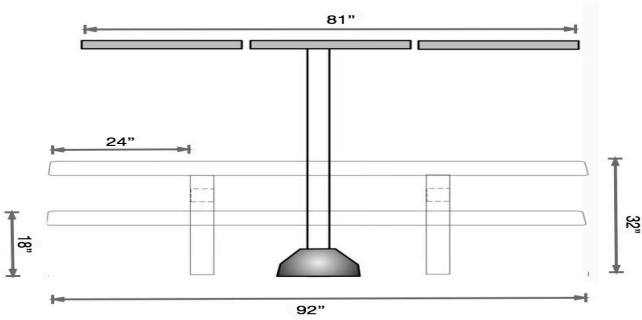

**Yosemite Shade Charger Picnic Table**  
External Dimensions



**Yosemite**

**SunnyCal Solar Inc**

Copyright 2018, All Rights Reserved

# COLOR: "SANDSTONE"



# Proposal to City of Seaside Neighborhood Improvement Commission

## SOLAR-POWERED PARK BENCH CHARGING STATION



CITY OF SEASIDE HOMELESS COMMISSION

# PROJECT PROPOSAL

- The Homeless Commission proposes the purchase of an outdoor solar-powered picnic-style park bench that serves as a charging station.
- Location: Stephen Ross Park Grass area (between Library and City staff portables).
- Current starting cost of one bench: \$6,999 + tax (possibly waive tax)



# BENEFITS

- Provides outdoor charging support for community members (Phones, Laptops, Tablets, etc.)
- Promotes fellowship and offers a nice spot to relax in the shade.
- Invites community to enjoy the park more frequently.
- Offers modern conveniences.
- Enhances park utilization.



# DESCRIPTION

## SunnyCal “Yosemite” Solar-Powered Picnic Table

- Concrete solar powered picnic table designed for remote outdoor locations.
- Provides two 120 volts AC outlets and six standard USB outlets.
- Weather and vandal resistant.
- Ready for use upon delivery. No setup Required.
- Twenty year expected service life.



# FEATURES

- (2) 120v receptacles and 6 USB outlets.
- 4-panel 800 watt solar module array and charge controller.
- 300 watt daytime inverter.
- GFCI protection and UL listed NEMA receptacles to prevent electrical shock in case of rainy weather.
- Optional 1440 Watt/Hour Battery for use when the sun is down (unlocks additional features) (\$1,223).
- Optional Automatic LED table lights (must have battery) (\$144)
- Optional Host 911 emergency phone (must have battery) (\$1,508).
- Optional tamper-resistant solar panel screws (\$340).



# STRUCTURE

- Industrial Strength Cast Reinforced Concrete table. Easy to Clean.
- Seats up to 8 comfortably with ADA compliant seating on both ends .
- Engineered pole mount system.
- Stainless steel welded frame.
- 90mph wind speed rated.
- Robust Ballast mount system minimizes panel movement.
- Heavy-duty components.



# DIMENSIONS

- Canopy Height (High side) : 9ft adjustable
- Canopy head clearance (low side): 6ft 6in
- Table: 7ft-8in long x 5ft-5in wide x 2ft- 8in high
- Canopy: 6ft-9in long x 4ft 10 wide
- Total weight: 2,650lbs  
(can be placed on grass, gravel or concrete)

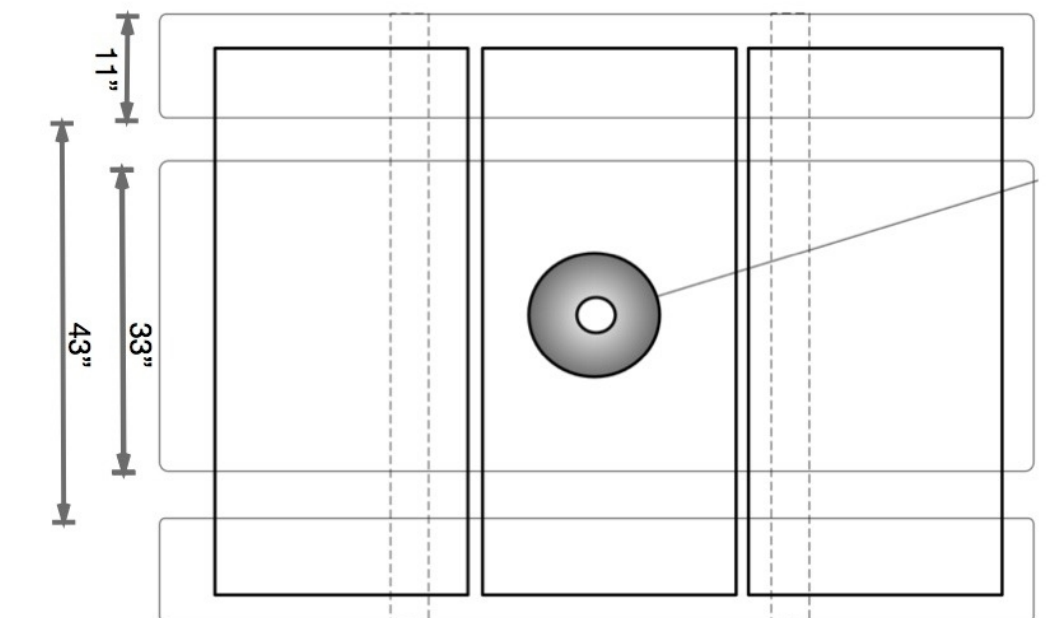
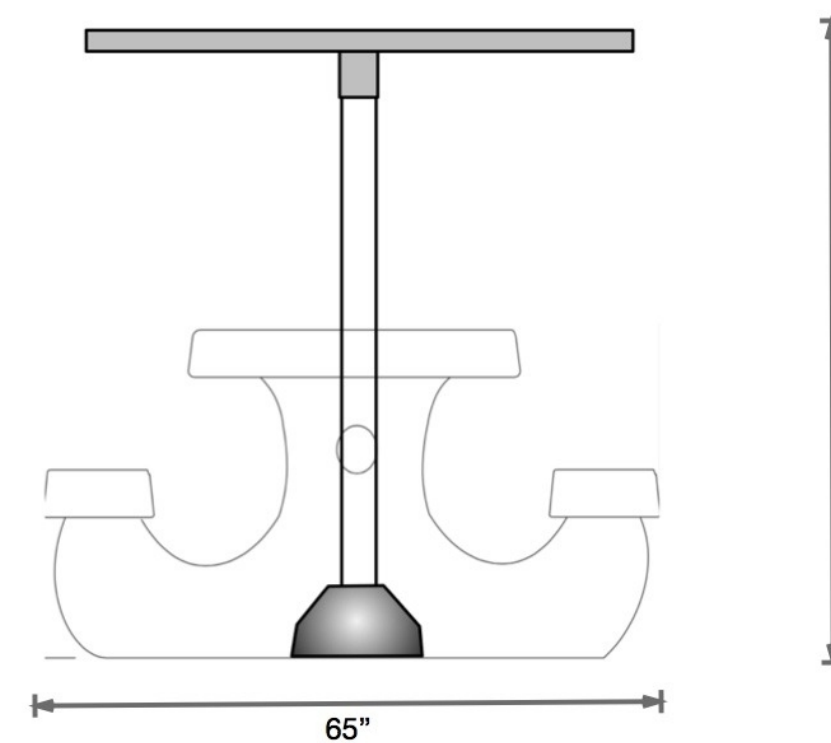
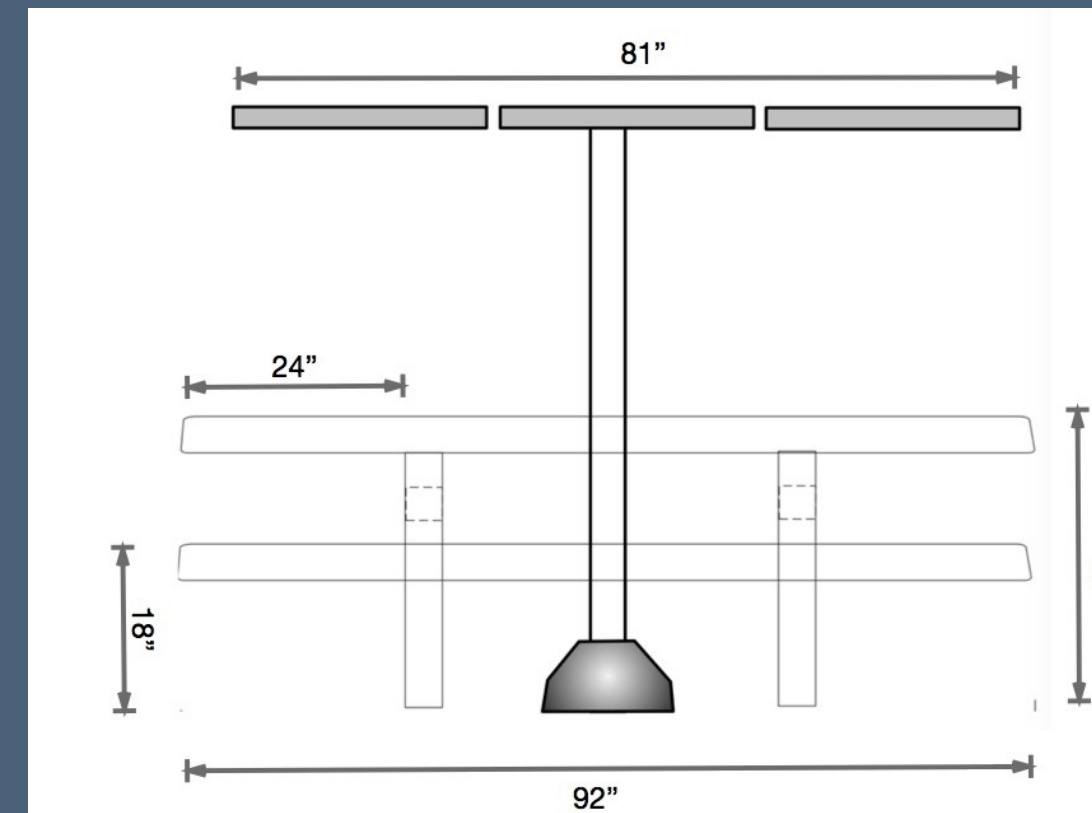

**Yosemite Shade Charger Picnic Table**  
External Dimensions



**SunnyCal Solar Inc**  
Copyright 2018, All Rights Reserved



# COLOR

“Sandstone”



# CONCEPT IMAGE

For Visual Reference Only



CITY OF SEASIDE HOMELESS COMMISSION

THANK YOU



CITY OF SEASIDE HOMELESS COMMISSION



The **Yosemite** is a solar powered ADA compliant picnic table that provides users electrical power to charge mobile devices and wifi internet service.

**Power    Wi-Fi    Lights    Speakers**

Safety features enable lights and emergency communications.

The Yosemite has fully autonomous operation; no wiring or cable installation is required. The ShadeCharger™ power module uses solar power to energize regular electrical outlets and USB ports at the table surface.

**Schools    Rest Areas    Sport Parks**

Yosemite table features:

- **Colored concrete or steel picnic table, 92" x 65"**
- **Overhead shade with 600W Solar Array**
- **Two 110Vac & Six USB power outlets**
- **Bluetooth Controlled Speakers (optional)**
- **Automatic LED table lights (optional)**
- **Wi-Fi internet service (optional)**
- **1440Whr Lithium storage battery and charger**
- **Galvanized steel components for high durability**
- **Host 911 emergency phone (optional)**
- **Concrete tables withstand 100MPH wind**
- **2-year Warranty**



***Prices start at \$6999+ tax***

**COLORED CONCRETE PICNIC TABLE**

Heavy duty picnic table with all-in-one table surface and seat pedestals. Dimensions 92"x65", 2500lbs.

**SOLAR SHADE ENABLES REMOTE PLACEMENT**

Overhead shade includes three solar panels to produce 600W of power for table power outlets. Available as add-on option to existing tables.

**110V & USB OUTLETS**

Two standard 110vac outlets and six 2.4/3A USB outlets at table surface powered by on-board power module with storage battery.

**Wi-Fi INTERNET**

Broadband access to internet and user email is optional via ShadeCharger.net™

**LED NIGHT LIGHTS**

Dual surface lights are automatically enabled in low light conditions.

**Security bolts** available for high risk areas

## Art & History Project Ideas for the NIC

### **1. Seahorse Statues & Sculptures**

- Cohesive design of all seahorse statues and sculptures in the City, some sculptures appear to be unfinished compared to others
- Financial Request = \$20,000

### **2. Mural**

- Proposed location - 705 Broadway Ave
- Requesting all available exterior wall space
- Financial Request = \$50,000

### **3. Seaside Stars Signage on Broadway**

- QR code signage signifying Seaside Stars Program--purpose, individuals, link to website information
- Signage and/or poles marking the location of Seaside Stars on Broadway
- Financial Request = \$10,000

<b><u>Project</u></b>	<b><u>\$\$\$</u></b>
Metz Park Improvements (Replace Picnic Tables)	\$ 3,000.00
Metz Park Improvements (Seal & Stripe Parking Lot)	\$ 10,000.00
Laguna Grande Park (Seal & Stripe Parking Lot)	\$ 15,000.00
Cutino Park (Seal & Stripe Basketball Court)	\$ 20,000.00
Trinity Park Improvement (repair entry/benches)	\$ 15,000.00
Manzanita-Stuart Park Improvement (signage, benches)	\$ 15,000.00
Dumpster Days	??
Community Cleanup (trash pick-up)	\$ 1,200.00
Public Trash/Recycling Receptacles	\$ 50,000.00
Pet Waste Stations	\$ 5,000.00
Lincoln Cunningham Playground Age 2-5	\$ 200,000.00
South Del Monte Landscaping	\$ 10,000.00

**Comments**

Listed in Facilities Condition Assessment 2023

Listed in Facilities Condition Assessment 2023

Listed in Facilities Condition Assessment 2023

Listed in Facilities Condition Assessment 2023

Repair to the entry areas on both sides and the benches

Park MP recommends Master Plan for park first, but also notes signage, benches, pavement repair, checking play area as considerations. **There is a 2019 Conceptual Plan.**

These help curb illegal dumping in the City. NIC already hosts 1-2, maybe another one? Maybe specific to hazardous waste?

Sponsor/host neighborhood cleanup days for trash pick-up. Cost would be for cleanup tools/event supplies, estimate \$200 for one. Cost would be reduced after initial purchase of cleanup tools. Up to six in the year. (Kirstin willing to help facilitate)

Rough estimate, but \$50k could probably get us 2-3 customized (City Logo & sorting signage) 2-stream receptacles. Suggested for Cutino or Laguna as a trial. Sturdier than current receptacles.

Additional pet waste stations, locations to be determined

Andreas

## Environmental Commission Project Ideas for the NIC

1. The Environmental Commission has recommended a request for **\$5,000** in funding for gardening equipment.
2. The Environmental Commission has also approved requesting **\$4,000** from NIC to support the **Herman Gull Fledgling Awareness and Signage Project** at the intersection of Calaveras and Broadway.
3. Additionally, the Environmental Commission has approved a request for **\$5,000** from NIC to support the "**Green House of the Month**" program.

To: Environmental Commission & Neighborhood Improvement Commission  
From: Kat Morgan, Vice Chair, Environmental Commission  
Date: October 27, 2025  
RE: Seaside's Heermann's Gulls

The contents of this memo were presented to the Environmental Commission on October 27, 2025, during the Commissioners Report section of our Agenda. In part, they reflect the contents of a conversation I had with the Director of Monterey Audubon on September 25. They should also prove useful to the NIC when they deliberate at their November 15<sup>th</sup> meeting.

### Heermann's Gulls: Background

95% of the Heermann's Gull population lives in Baja California, on tiny Isla Rasa (a quarter square mile) and only a couple other neighboring islands. **Seaside is the only other place in the world where these birds nest.** They have done so since 1999. Seaside is a very special and important place for these birds.

This species is vulnerable, and the Seaside colony is critical to their survival. An unfortunate consequence of their Baja concentration is that if something happens to the fish population they feed on there or a hurricane were to hit during breeding season, the southern population could be decimated. The likelihood of both threats is increased by ocean and climate change, which is accelerating. In the past they have experienced near total nesting failure in Baja. They are considered Near Threatened by the IUCN (International Union for Conservation of Nature) and a Bird of Conservation Concern by the U.S. Fish and Wildlife Service.

I'm sure you've seen them. They are an easy-to-identify gull. Their breeding plumage are mostly deep gray with a pearly white head, and most distinctively, a brilliant red bill. Immature Heermann's are dark sooty brown. It's also possible you've seen dead fledglings on Broadway during nesting season — these birds do not yet know how to fly and are easy prey for cars speeding down this main artery.

### City of Seaside's Relationship and Response to Our Unique Heermann's Gulls Colony

We are fortunate — City staff are already working with our local Audubon chapter. I want to commend those staff on this partnership and publicly thank Monterey Audubon staff and volunteers for their leadership and stewardship.

I urge the City to continue this partnership and take guidance and leadership from Audubon going forward.

I also want to acknowledge an unfortunate but predictable consequence of Heermann's Gulls roosting on buildings along Broadway — especially at the intersection of Calaveras and Broadway. Their guano does stink. They do make a mess on rooftops and sidewalks. Perhaps you've seen this as well. And dead fledgling gulls often litter the street during breeding seasons.

It's understandable that businesses along this stretch of road complain and wish the gulls would nest somewhere else. Addressing this certainly falls under the NIC's objectives.

A gull crossing sign like the sign on Canyon del Rey in front of City Hall could go a long way towards preventing part of this problem – gull roadkill along lower Broadway – and could also raise awareness among Seaside residents. The EC recommended this for funding by the NIC at our October 27<sup>th</sup> meeting.

I understand that City staff are framing Seaside's response as "gull abatement." The term abatement concerns me; it often means eradication. I recommend this framing shift to "management." I'm not quibbling about a single word here — these phrases reflect assumptions and goals. I certainly think we should be aiming for peaceable coexistence with Heermann's Gulls rather than "abatement," especially because of their conservation status and Seaside's important role.

Among responses City staff are considering is netting those buildings on Broadway. This is understandable, but likely to fail. The challenge is gulls will be gulls, and this will just drive them elsewhere, likely to neighboring buildings. This simply relocates the problem. It could represent a waste of resources.

What we and the gulls need is habitat restoration — Roberts Lake comes to mind. Certainly, this isn't a near-term solution, but the sooner plans are made, the sooner these unique gulls could have a home more hospitable to both humans and birds. I urge the City to begin such planning immediately.

In the meantime, I understand Monterey Audubon has other ideas that could address the consequences while also protecting the birds: responses that could be near-term. I urge City staff to explore these and help make them happen.

Note: I know the local Monterey Audubon Director, a Seaside resident, would welcome the chance to present to the EC at a future meeting and answer any questions other Commissioners may have that are beyond my ability to answer.

# FOSPA Recommendations

## NIC Projects 2026-2027



# FOSPA Recommendations for 2026-2027 NIC Projects



1. Capra Park - Accessible Parking Lot and Pathway
2. Boulders in FOSPA Parks
3. Water Refilling Stations in FOSPA Parks
4. Two - five year old playground at Lincoln Cunningham Park

# Capra Park

Thanks to NIC and Seaside Public Works, many improvements were made in 2025, including

- a retaining wall
- an extended picnic area
- new picnic tables and benches
- a barbeque
- a water refilling station



# #1 ADA Parking & Accessibility for Capra Park

The part of the Capra Master Plan that remains unfulfilled is resurfacing the now defunct parking lot with two ADA accessible parking places, with the driveway accessed from Luzern Street.



Driveway from Luzern showing where parking spots would go.

# #1 ADA Parking & Accessibility for Capra Park

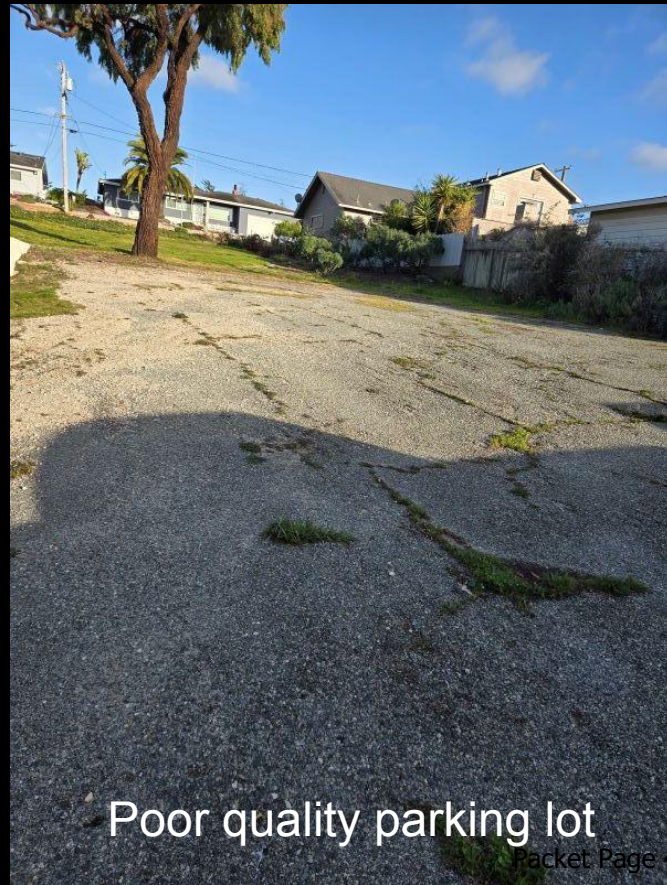

Poor quality parking lot

# #1 ADA Parking & Accessibility for Capra Park

An ADA pathway from the parking lot to the lower-level food garden, new picnic area, and lower play structure would greatly improve the overall accessibility of Capra Park.



# #1 ADA Parking & Accessibility for Capra Park

SONOMA AVENUE

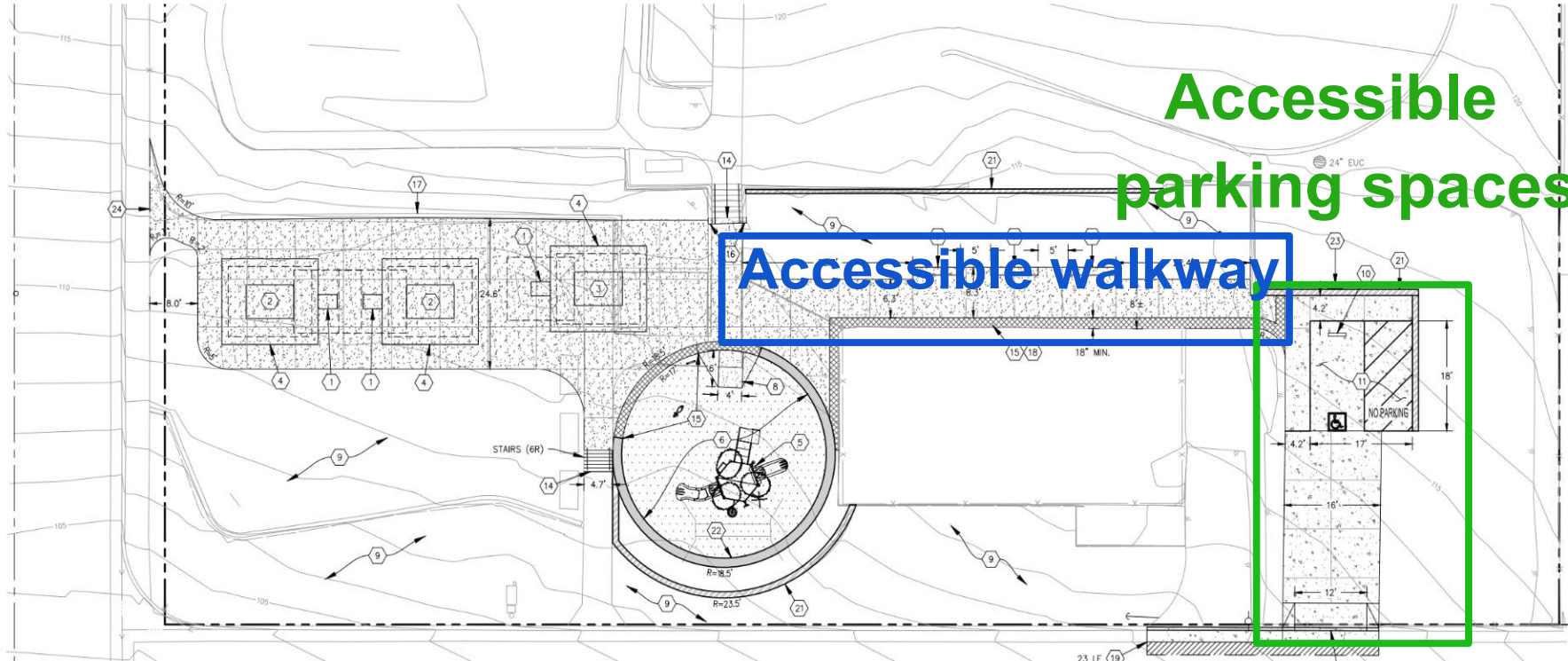

Accessible parking spaces

Accessible walkway

From the Capra Park Master Plan

LUZERN STREET

Packet Page 44



## #2 Boulders in FOSPA Parks Durant, Havana Soliz, Lincoln Cunningham

Boulders in parks  
enhance the  
landscaping and create  
visual interest.  
They can provide  
natural borders and help  
prevent erosion.



## #2 Boulders in FOSPA Parks - Durant, Havana Soliz, Lincoln Cunningham

In addition to adding natural beauty, boulders provide basking and warming spots for pollinators, habitat for crevice nesters, dew-catching for water, and mineral sources.



## #2 Boulders in FOSPA Parks Durant, Havana Soliz, Lincoln Cunningham

The addition of more  
boulders would provide

- natural beauty
- erosion control
- habitat for various  
species





### **#3 Water Refilling Stations at Beta, Durant, Farallones and Martin Park**

Water refilling stations at FOSPA parks (that have water access) would add a convenient amenity to those locations.

## #5 Two-Five year old playground at Lincoln Cunningham

With the help of NIC funds, Lincoln Cunningham Park now has a shade structure, picnic tables, barbeques and a soon-to-be-installed five to twelve year old playground.



FOSPA is currently expanding the main pollinator garden to include adjacent areas.

## #5 Two-five year old playground Lincoln Cunningham



## #5 Two-five year old playground Lincoln Cunningham



The two-five  
year old  
playground is  
the next area  
FOSPA would  
like to see  
developed.

# #5 Two-five year old playground equipment Lincoln Cunningham Park

FOSPA thanks the Neighborhood Improvement Commission for their contributions to this park and appreciates their consideration of this next project that will help this park become a point of pride for this neighborhood and the City.

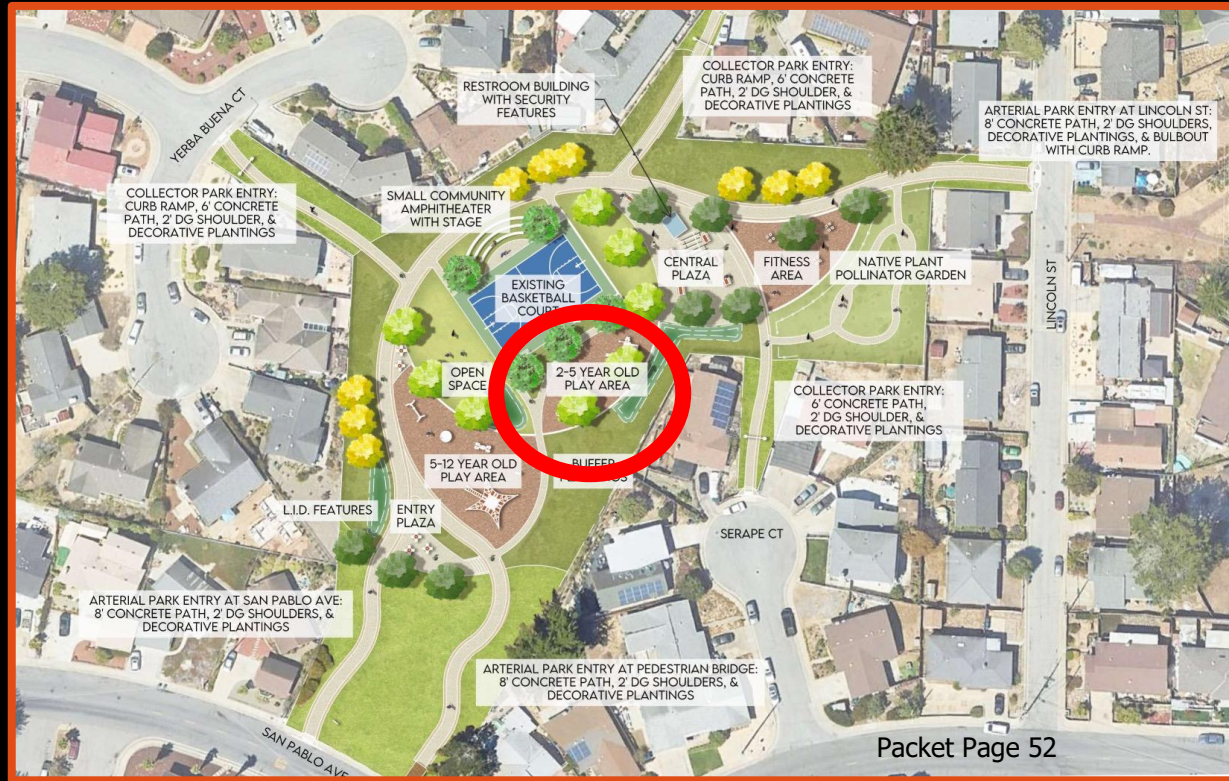

Thank you!



## Parks and Recreation Commission Project Ideas for the NIC

1. \$100K to be allocated for an indoor gym. Money to be put into an account to build on.
2. \$50K for an additional dog park on the north end of Seaside
3. \$35K to fund the renovation of pathways in parks (Beta Park)
4. \$5K for the annual tree give-away program

Private Citizen-Anthony Amarante- NIC Project Ideas

I would like to suggest the properties at 1317 Hilby Ave (corner of Hilby and Noche Buena) and 1401 Sonoma (corner of Sonoma and Judson) as two properties where the owners may appreciate a gentle reminder that some of their belongings should be put in storage?

## Private Citizen-Emily Gottlieb-NIC Project Ideas

I'd like to propose a project to the NIC for 2026/27 to increase the annual tree give-a-way project by \$5,000. I understand that this program has been successful, and expanding the program would support elements of the city's Climate Action and Adaptation Plan, specifically implementation measure UGT1: Tree Planting.

## Private Citizen-Lynda Cunningham-NIC Project Ideas

- 1) Big Ass Fan for the Oldemeyer Center – It needs air movement in the large interior room.
  - One Big Ass Fan (the real name of the company) could do the trick. [Big Ass Fans](#)
- 2) Soper Community Center is unbearably loud when people are mingling and talking. The noise just bounces off the walls in ever increasing volume as people speaker louder and louder to be heard.
  - There are sound reducing panels that can be produced with your own photos, or art, that would reduce the echo's and bring the beauty of Seaside & Monterey Bay to this space.
  - Turn 12 restaurant in Monterey has sound reducing panels that makes it a nice place to eat. It's where I learned about this tech. Monterey Spine & Joint (now Montage something) uses panels hanging from the ceiling at the check in desk to provide privacy for clients.
  - These panels are not that expensive and would make that community room more enjoyable to be in.

### [Acoustimac | Acoustic Panels, Bass Traps and Soundproofing Materials](#)

- 1) Paint all the traffic light poles that are run down, chipped, stickers...
  - La Salle and Fremont are bad.
- 3) AT&T building on Broadway – what an eye sore
  - Fence – needs updated – the school up the hill has better looking fencing.
    - o Do we need an ordinance banning Razor Wire? – There is better fencing tech that looks good
  - The building needs painted. The graffiti has been painted over with a multitude of paint colors that do not match the building. It looks terrible.
    - o I see the 2 west most “panels” as great places for murals  
One could be Seaside History – Doc Roberts, Army, the giant Oak Tree...  
One could be Seaside Future – Sunday Blues, University, Golf Courses, Thriving Downtown....
  - The gate on the east side by the bakery – ugly. The signage needs to be presented better.
  - AT&T is took-in \$14 billion last year – they can afford a new fence, paint, and spruce up.

## Seaside Community Safety Advisory Commission Project Ideas for the NIC

Seaside Community Safety Advisory Commission Meeting, our commissioners agreed to submit the following suggestions to the Neighborhood Improvement Commission. Mescal/Neil Park is being used as an example:

1. Residents have noticed several possible safety issues because of deteriorating asphalt on walkways and sidewalks. (See attached pictures) We understand that re-paving the sidewalks is an additional expense for the city, but if residents could be provided with a timeline of when these issues might be addressed, it would be a big help.
2. A very diligent group of residents maintains a nice pollinator garden on a regular basis, but there is no raking and or removal of leaves from sidewalks and walkways on the north side of the park. There are so many fallen leaves that they completely cover up the sidewalk and present a safety issue for people walking. Monthly maintenance and cleanup by city workers would easily resolve the problem. (See attached pictures) Per our commissioners, this problem also exists in more parks in addition to Mescal/Neil.
3. The only way to access the newly installed benches to sit down and enjoy the beautiful views is to walk across uneven and unstable chips and ground cover. Is it possible to create dedicated safe paths and/or walkways that lead to the benches? (See attached pictures) Currently, it is unsafe for elderly residents and children to attempt to walk across the chips and uneven ground cover.

Yvonne Thomas  
Vice Chair  
Seaside Community Safety Advisory Commission







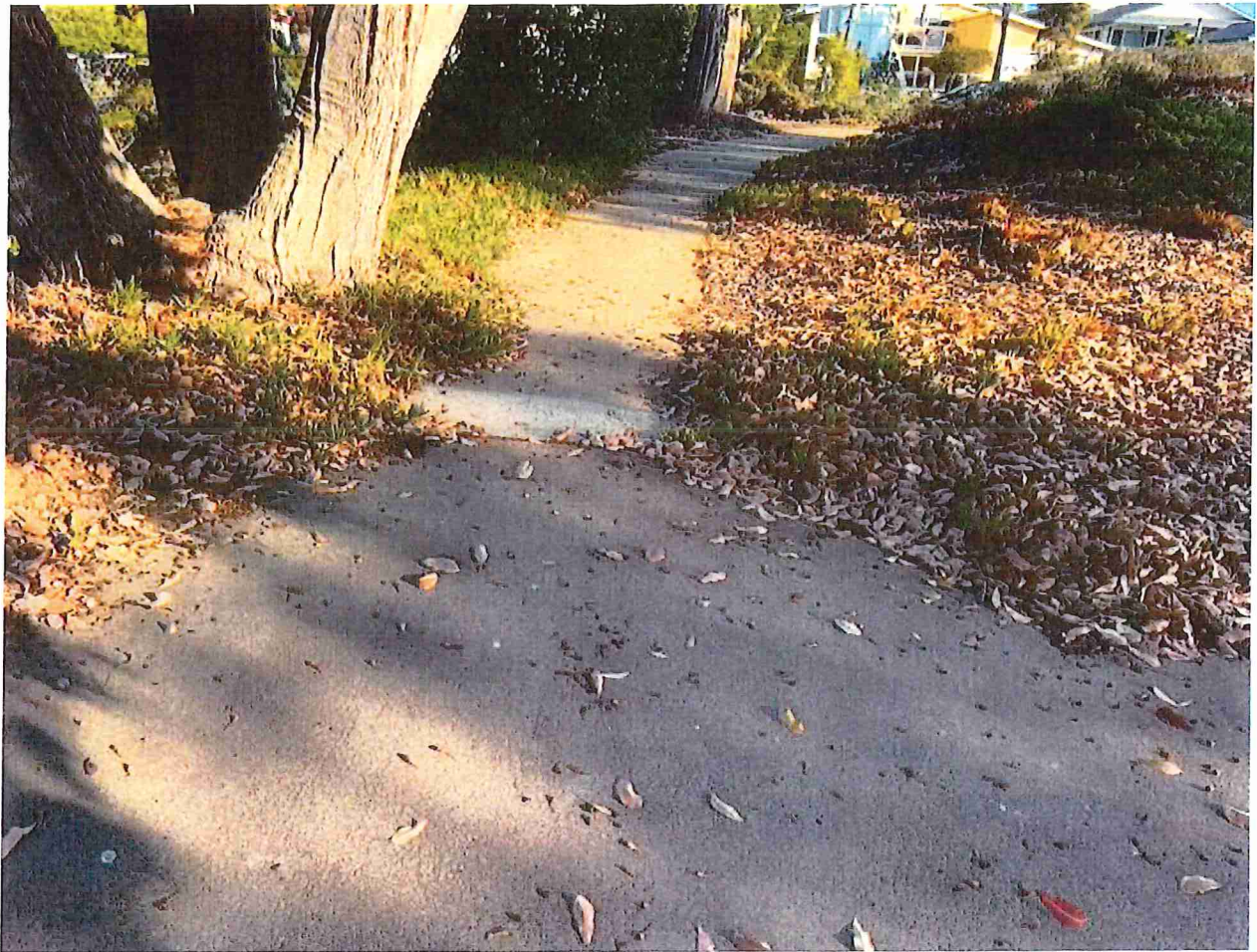

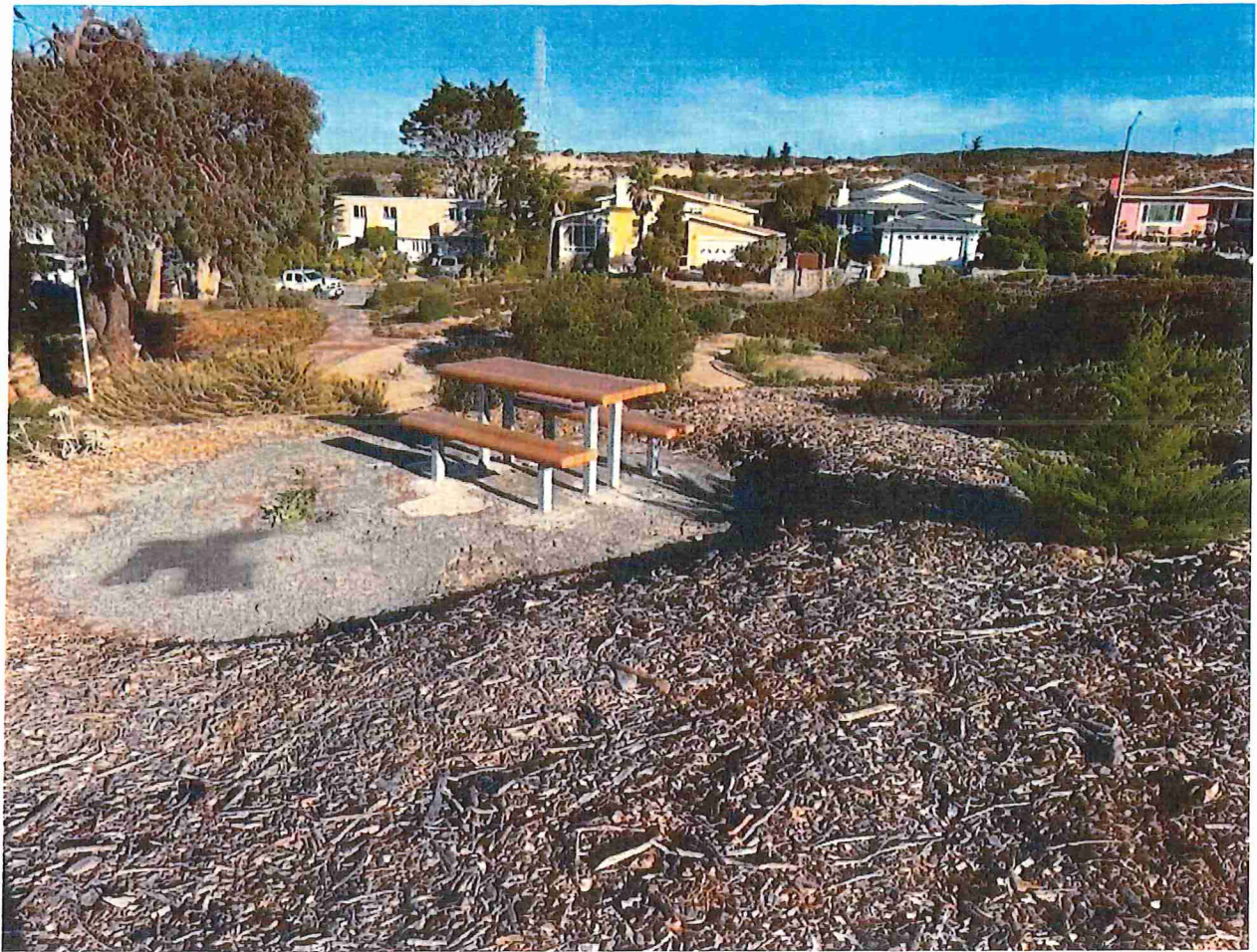

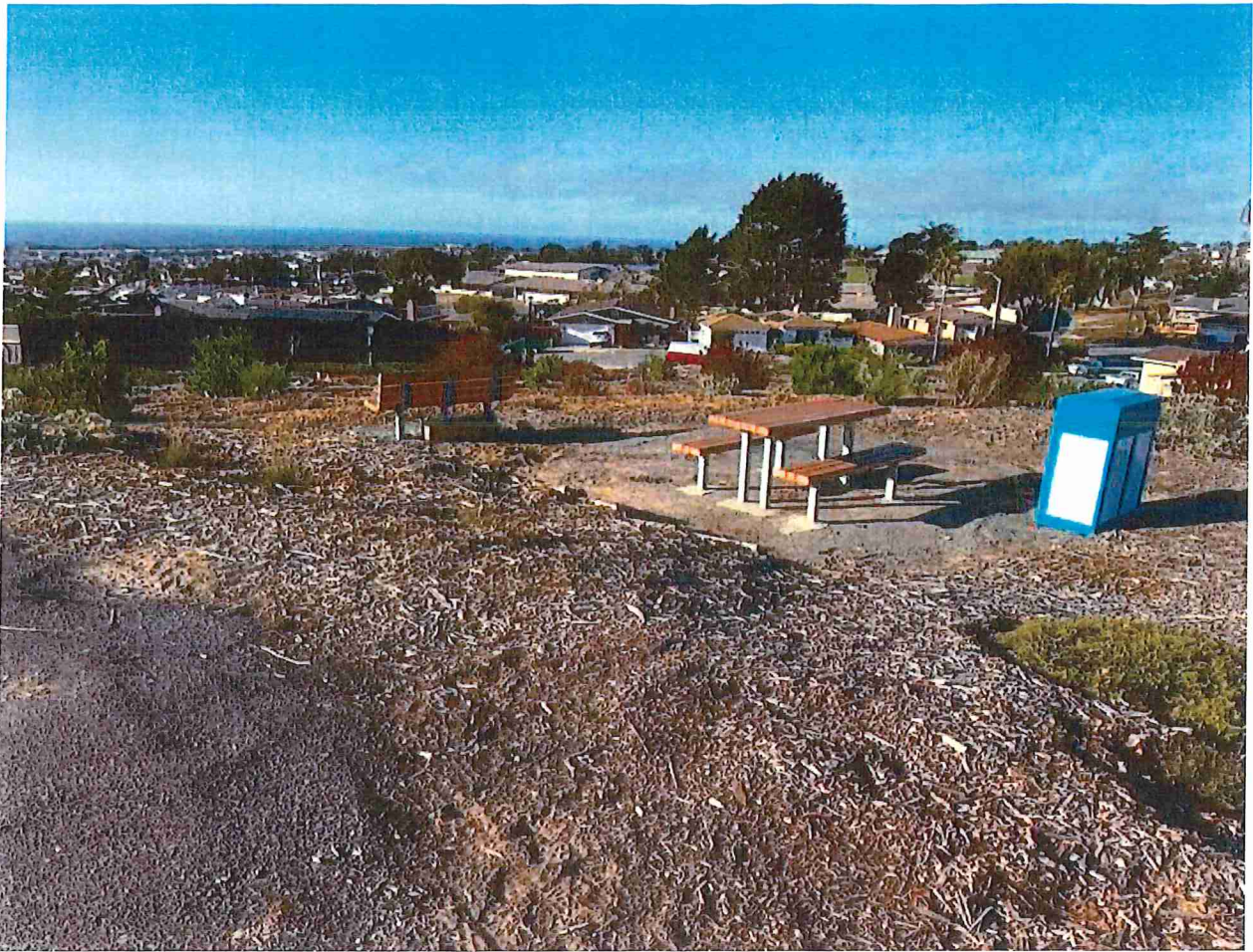

Sincerely,

Yvonne

*Yvonne D Thomas*  
MEDIA CONSULTANT

[818-930-0003](tel:818-930-0003)

[yvonnethomas13@gmail.com](mailto:yvonnethomas13@gmail.com)

On Nov 3, 2025, at 4:54 PM, Daniel Meewis <DMewis@ci.seaside.ca.us> wrote:

I still can not see them.

## Sustainable Seaside Project Ideas for NIC 26-27

Sustainable Seaside would like to submit the following project proposals.

### **1. Toddler Playground (Ages 2–5) at Lincoln Cunningham Park**

Create a dedicated, age-appropriate play area designed specifically for toddlers, offering safe, inclusive play opportunities for young children and caregivers in the surrounding neighborhoods.

### **2. Water Refilling Stations in FOSPA Parks**

Install public water bottle refill stations in Friends of Seaside Parks Association (FOSPA) parks, including **Beta, Durant, Farallones, and Martin Parks**, to support hydration, reduce single-use plastic waste, and encourage healthy outdoor recreation.

### **3. Fort Ord National Monument Gateway Signage**

Add clear, welcoming signage at the **Gigling Road and General Jim Moore Boulevard entrance** to better identify Seaside's gateway to Fort Ord National Monument, improve wayfinding, and highlight Seaside's role as a primary access point to this major regional asset.

### **4. Benches and Outdoor Fitness Equipment Near Playgrounds**

Install benches and outdoor workout equipment adjacent to playground areas in city parks to support caregivers, multigenerational use, and informal physical activity while children play.

### **5. Permanent Performance Stage at Laguna Grande Park**

Develop a modest, permanent outdoor performance stage to support community events, cultural performances, school programs, and neighborhood gatherings in one of Seaside's most heavily used and beloved parks.

### **6. Seaside Visitor Guide / Magazine**

**Create a visitor guide or small magazine that highlights Seaside's distinct character and positions the city as a destination for eco-tourism, family-friendly recreation, and arts & culture audiences. Content could include:**

- **Seaside's history and diversity**, shaped by deep ties to Fort Ord, which brought people from around the world and helped create one of the most ethnically diverse cities on the Monterey Peninsula, which is reflected in food, community events, and a vibrant arts and culture scene.
- **Access to the Monterey Bay Coastal Recreation Trail**, which runs along Seaside's waterfront and connects to Monterey, Pacific Grove, and Marina, offering world-class opportunities for biking, walking, and enjoying ocean views.
- **Seaside's outstanding food scene**, known regionally for authentic local Mexican food (taquerias, bakeries, and family-run businesses), as well as strong Filipino, Vietnamese, and multicultural dining options.
- **FOSPA parks as living examples of community stewardship**, supporting family-centered recreation, pollinator habitats, and sustainable

eco-landscapes, many with some of the most spectacular views of Monterey Bay.

- **Seaside as a primary gateway to Fort Ord National Monument**, one of the largest urban-adjacent trail systems in California, offering hiking, mountain biking, trail running, horseback riding, seasonal wildflowers, and wide-open landscapes.
- **Laguna Grande Regional Park** as a signature green space featuring walking paths, picnic areas, wetlands, and birdlife, a peaceful park with a grassroots, inclusive, and high community-use character.

Thank you for the opportunity to consider and submit ideas for consideration.

Sincerely,  
Catherine Crockett  
Chair, Sustainable Seaside  
[\(831\) 915-7257](tel:(831)915-7257)



**CITY OF SEASIDE  
STAFF REPORT**

**Item No.: 6.F.**

**TO:** Neighborhood Improvement Program

**BY:** Dan Meewis, Assistant City Manager

**DATE:** January 10, 2026

**SUBJECT: DISCUSSION ON THE BUDGET FOR PROJECT PROPOSALS**

---

**RECOMMENDATION**

**BACKGROUND**

The Neighborhood Improvement Commission considers and recommends projects intended to benefit the community and enhance neighborhood quality of life. Project proposals are typically subject to available budget appropriations approved by the City Council.

As project costs and community needs evolve, it is important for the NIC to periodically review and discuss the budget framework for project proposals. This helps ensure transparency, fiscal responsibility, and alignment between proposed projects and available funding.

**ATTACHMENTS**

None

---